

ASA

AIRPORT SERVICES ASSOCIATION



LEADERSHIP FORUM

In association with ARGS

20th - 22nd September 2023
Grand Hyatt, Athens

ASA members benefit from:

- 10% off sponsorship and exhibition bookings
- 15% off the delegate rate
- Extra 5% reduction if you register by 31st of March

Become an ASA Member

**The voice of the ground
service industry**

Conference Brochure



Event Overview

We are excited to announce the 2nd Airport Services Association Leadership Forum after a successful 2022 event. This will be held from the 20th - 22nd September 2023 in Grand Hyatt Athens.

This is the official gathering that represents over 50 international ground service providers, we have created an event that brings together all stakeholders within the world of ground handling services.

The ASA Leadership Forum is targeted at senior decision makers responsible for the procurement and selling of ground services including refueling, passenger handling, baggage handling, aircraft service/line maintenance, ramp handling, catering and lounge services.

This is the place to meet with the procurement managers of ground services from the airlines.

The ASA Leadership Forum creates an environment to build new long term business partnerships with your airline partners.

Airport Services Association Conference 2023



Exhibition Space

- 2.5 x 2.5m SPACE + TABLE AND CHAIRS £6,500
- 2.5 x 5m SPACE + TABLE AND CHAIRS £12,000

What our team will deliver to our exhibitors:

- All graphics will be printed, delivered and put up prior to your arrival– simply supply the design (Specifications will be emailed)
- All furniture, electrics and lighting will be set up and completed before arrival - extra furniture is available on request
- If you are sending your brochures and/or promo items, these will be delivered to your booth
- Tell us who you wish to meet - leave the rest to us. We will orchestrate your meetings with our well-established and complimented 1-2-1 Meeting System
- All Exhibitors - Participation in the conference
- 2 free delegates
- Logo placed on all marketing material
- Company logo displayed on conference website

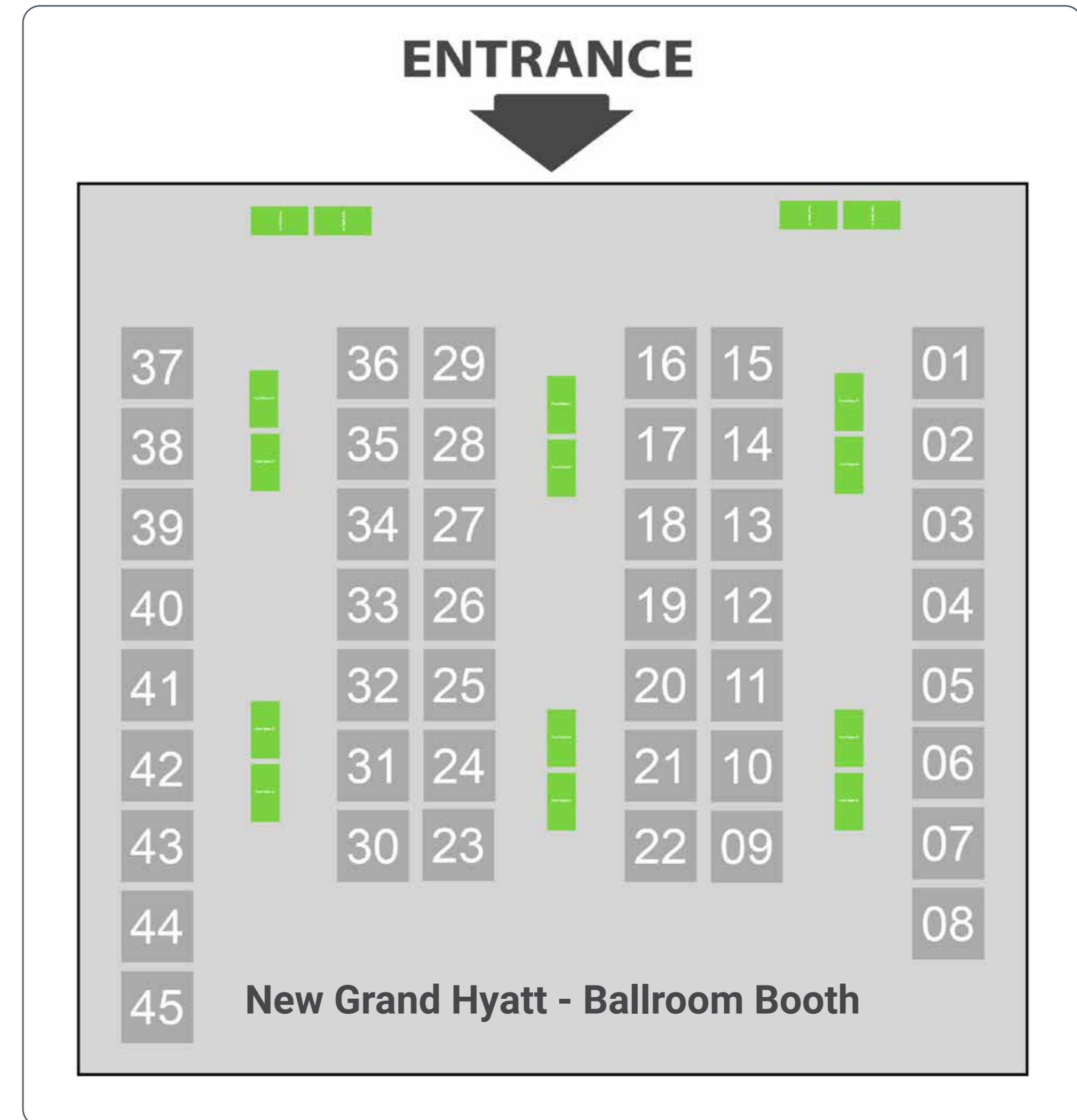

For exhibition and sponsorship enquiries, please contact:

Humza Raja | +44 (0) 208 253 4005 | humza@evaint.com

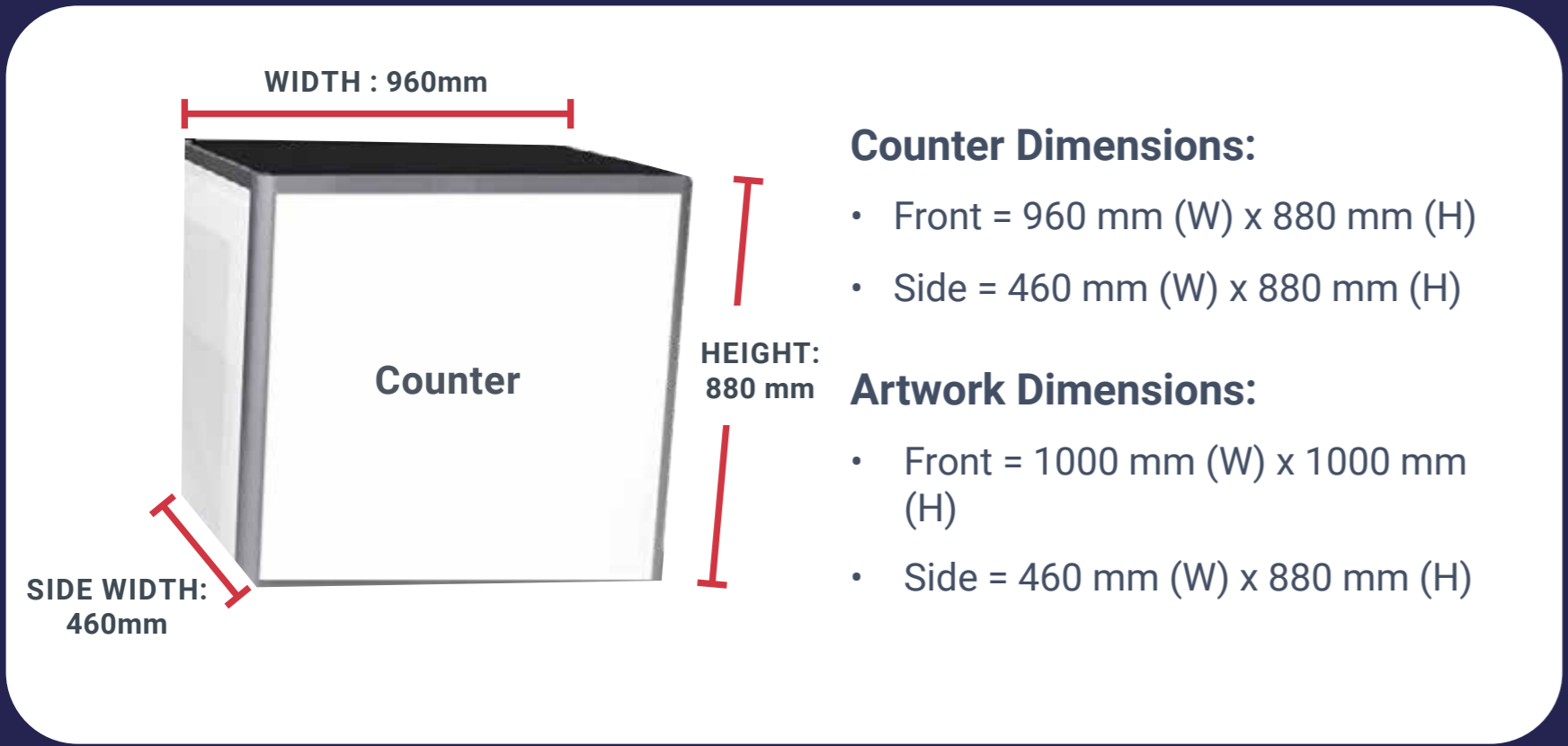

This is how we need your graphic data:

Vinyl print on the wall:

- Colours saved in CMYK 4C mode
- Images should be embedded and also flattened
- Transparent artwork must be flattened
- No embedded colour profile
- Texts and fonts converted to paths/outlines
- Resolution: min. 150 dpi
- Fills and strokes should NOT be set to 'overprint'
- No bleed area & no trim marks

We will accept the following file formats:

Photoshop: .eps, high-res.jpg, .tif • Illustrator: .ai, .eps • Acrobat PDF: print .pdf

Please note that MS Office files cannot be used for artwork. If you have .cdr files please have them exported to .eps.

Lettercut logo, text: (Please supply the following)

- .ai or .eps (vectorised)
- Font/letter type
- Pantone/colour mix

When we need your artwork:

Please send us your ready to print data no later than 24th June 2023.

Single Stand:



Backdrop Dimensions:

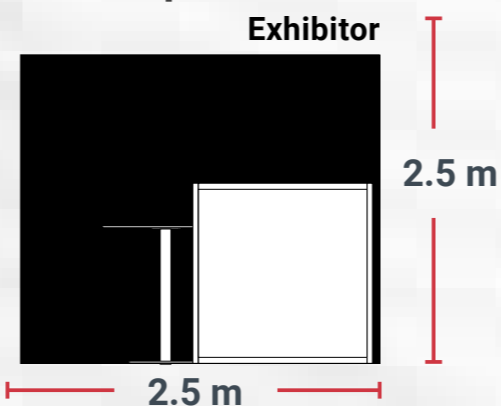

Double Stand:



Backdrop Dimensions:



Showcase your products & services

It is our objective to provide you with exhibition artwork of maximum quality. To achieve this, we have drafted guidelines with important information, specifications on the configuration and compilation of your data files. If your artwork is prepared by an agency, we kindly ask you to forward these guidelines to your business partner.

Vector graphics:

These imprint a surface by means of geometric data. Vector graphics can be enlarged as required without loss of quality and well suited for any kind of printed matter.

Raster graphics:

These consist of pixels and are unsuitable for film/foils. The quality depends essentially on the resolution of the original file. File Enlargement capability is limited.

Artwork specifications:

Please see the diagram to the left for exhibition stand artwork requirements.

- 2500 mm (Width) x 2500 mm (Height)

Please ensure all important text and images are within the Live Area to avoid the possibility of being cut off.

- 2300 mm (Width) x 1620 mm (Height)

Data transmission:

We kindly ask you to make your data and layouts available to us by sending them to:

- Gemma Keen, Event Coordinator: gemma@evaint.com
- Alpha Diallo, Graphic Designer: alpha@evaint.com

Colours:

To best reproduce your corporate identity colour values, we need accurate colour information, e.g. HKS, Pantone or RAL values. You can also send us a master colour proof. If no hard proof is provided, the exact colour reproduction cannot be guaranteed.

Font spacing:

For large-format printing, fonts must have a sufficiently wide margin to the border. Especially for banner production with hemstitch seam and eyelets, enough margin space is required so the print does not spread across it.

Large-area graphics on system wall:

You are welcome to provide us one single file also for large-area graphics that are to be transposed across several wall elements. When creating your graphic designs, please keep in mind that the booth support struts will cut through the images. There should be no important image segments, texts or logo parts at these sections.

Black bar & company name:

The black bar with your company name in bold white text, will be added to your design by the printers. If you want your company name to be changed on the exhibition stand please inform Gemma with the new name. Include it in the email with your artwork.

Diamond Sponsor (1x available)

- Exhibition stand space:
2.5m (w) x 2.5m (d) x 2.5m (h)
- 6 Delegate passes
- 8 free customer passes
(Airlines or Freight forwarders only)
- Sponsor logo to appear on event website, marketing material and conference rooms
- Company brochure to be included in delegate bags
- Sponsor acknowledgement at closing of event

ASA = £15,000

ASA + ACHL = £30,000

ASA + ACHL + airfreight pharma/Pharma.aero = £45,000



Platinum Sponsor (1x available)

- Exhibition stand space:
2.5m (w) x 2.5m (d) x 2.5m (h)
- 5 Delegate passes
- 6 free customer passes
(Airlines or Freight forwarders only)
- Sponsor logo to appear on event website, marketing material and conference rooms
- Company brochure to be included in delegate bags
- Sponsor acknowledgement at closing of event

ASA = £13,000

ASA + ACHL = £26,000

ASA + ACHL + airfreight pharma/Pharma.aero = £39,000



Gold Sponsor (1x available)

- 4 Delegate passes
- 4 free customer passes (Airlines or Freight forwarders only)
- Sponsor logo to appear on event website, marketing material and conference rooms
- Company brochure to be included in delegate bags
- Sponsor acknowledgement at closing of event

ASA = £10,000

ASA + ACHL = £20,000

ASA + ACHL + airfreight pharma/Pharma.aero = £24,000



Silver Sponsor (3x available)

- 3 Delegate passes
- 3 free customer passes (Airlines or Freight forwarders only)
- Sponsor logo to appear on event website, marketing material and conference rooms
- Company brochure to be included in delegate bags
- Sponsor acknowledgement at closing of event

ASA = £8,000

ASA + ACHL = £16,000

ASA + ACHL + airfreight pharma/Pharma.aero = £24,000

Bronze Sponsor (3x available)

- 2 Delegate passes
- 3 free customer passes (Airlines or Freight forwarders only)
- Sponsor logo to appear on event website, marketing material and conference rooms
- Company brochure to be included in delegate bags
- Sponsor acknowledgement at closing of event

ASA = £6,000

ASA + ACHL = £12,000

ASA + ACHL + airfreight pharma/Pharma.aero = £18,000



Networking Dinner

- One of the highest level sponsors of the event with branding on ALL marketing material
- Your logo and branding will appear on the front of all Networking Dinner materials and menus
- Your sponsorship will be acknowledged during the Conference
- Logo and listing on the website
- Promoted as Networking Dinner Sponsor on all social media and press communications (as appropriate)
- Prominent sponsor logo on all banners, pop-ups, posters, e-marketing, website and advertising before, during, and after the event
- 4 free delegate passes
- 8 free airline passes (Airlines or Freight forwarders only)

ASA = £15,000

ASA + ACHL = £30,000

ASA + ACHL + airfreight pharma/Pharma.aero = £45,000

Airport Services Association Conference 2023





Welcome Reception Sponsor

- Bonus brand exposure in co-located areas within the ACHL, Airfreight Pharma & ASA Global Event
- One of the highest level sponsors of the event with branding on ALL marketing material
- Your logo and branding will appear on the front of all Welcome Reception materials
- Your sponsorship will be acknowledged during the conference
- Logo and listing on the website promoted as Welcome Reception Sponsor on all social media and press communications (as appropriate)
- Prominent sponsor logo on all banners, pop-ups, posters, e-marketing, website and advertising before, during, and after the event

ASA = £8,500

ASA + ACHL = £17,000

ASA + ACHL + airfreight pharma/Pharma.aero = £25,500

Hotel Key Cards

(Exclusive Sponsor)

- The exclusive sponsorship for the hotel key cards at the co-located ACHL, Airfreight Pharma & ASA Global Event
- Company logo branded room card sleeves to promote your brand throughout the venue hotel
- Your logo in a prominent headline position on promotional material (online and in print)
- All pre-event marketing mailings will include your logo and link to your website
- Listed as a sponsor on all event materials
- Logo in a prominent headline position on the day of the event

ASA = £7,500

ASA + ACHL = £15,000

ASA + ACHL + airfreight pharma/Pharma.aero = £22,500



Lunch Day 1, 2 & 3

- Bonus brand exposure in co-located areas within the ACHL, Airfreight Pharma & ASA Global Event
- Host sponsors of three day lunch to delegates
- 1 delegate pass
- Company branding to appear on table flags during lunches
- Sponsor logo to appear on event website, marketing material and conference rooms
- Company brochure to be included in delegate bags
- Sponsor acknowledgement at closing of event

ASA = £6,500

ASA + ACHL = £13,000

ASA + ACHL + airfreight pharma/Pharma.aero = £19,500

Airport Services Association Conference 2023



Wi-Fi Sponsor

(Exclusive Sponsor)

- The exclusive sponsorship for the Wi-Fi at the co-located ACHL, Airfreight Pharma & ASA Global Event
- A strong visibility option for any company that wishes to put their brand across to the entire audience. Get all participants to use your company name as the Wi-Fi password
- Company logo, profile and web link on the conference website
- 1 delegate pass
- Sponsors recognition on all promotional material i.e. roll up banners, within conference rooms during the event

ASA = £6,500

ASA + ACHL = £7,500

ASA + ACHL + airfreight pharma/Pharma.aero = £8,500



Registration Desk

SOLD

- High profile company branding on the event registration desk
- Accreditation as a sponsor of the event on registration desk
- The right to brand and distribute marketing materials from registration desk
- Logo, web link, and company profile on the conference website
- 1 delegate pass
- Opportunity for sponsors to display company roller banner stand within venue registration

ASA = £6,500

ASA + ACHL = £13,000

ASA + ACHL + airfreight pharma/Pharma.aero = £19,500

Airport Services Association Conference 2023

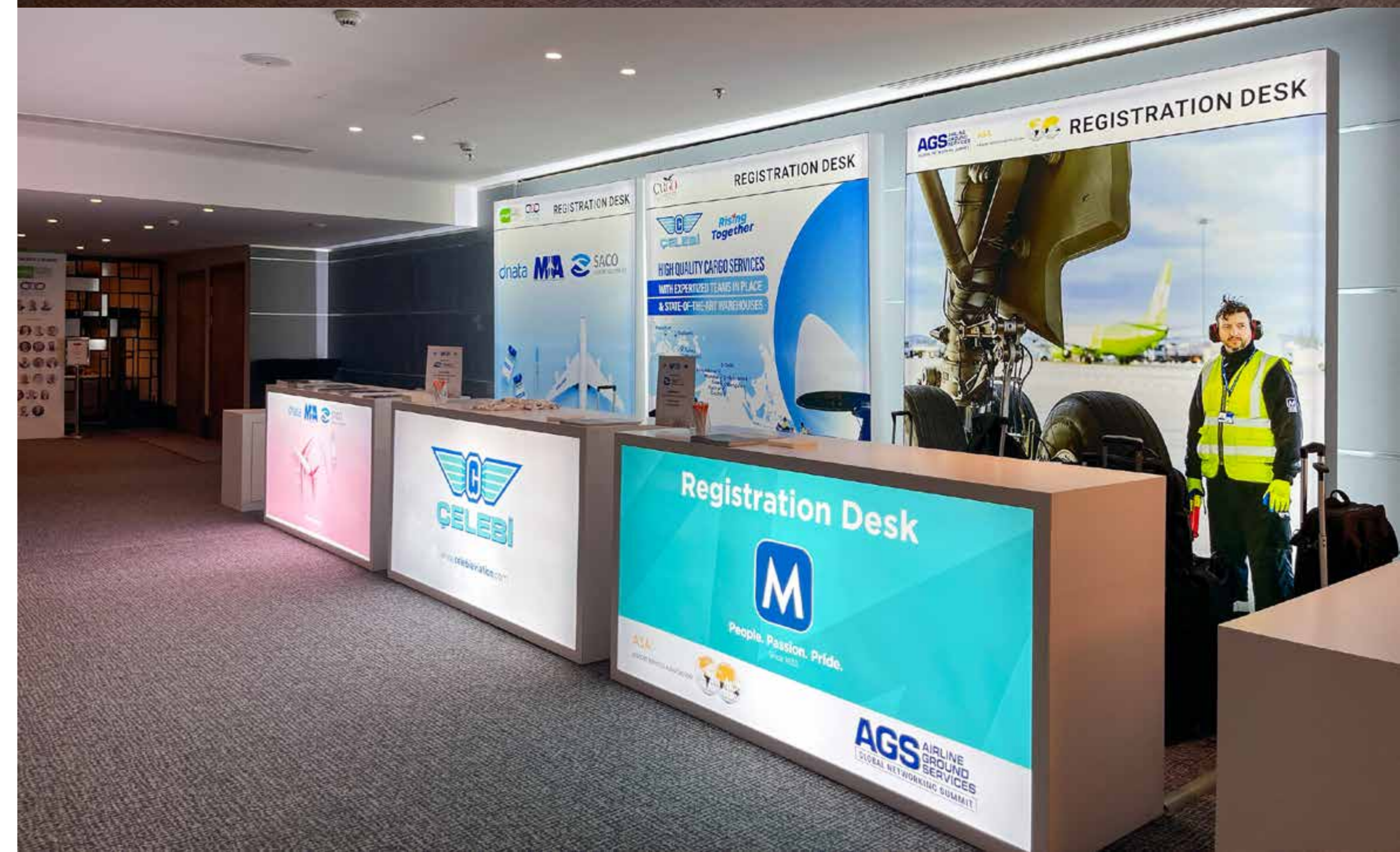

Badge & Lanyard

- Sponsors logo and corporate image on badges handed out to every delegate during their registration arrival (Design by organisers) - Lanyards to be provided by sponsor
- Company logo, profile and web link on the conference website
- 1 delegate pass
- Sponsors recognition on all promotional material i.e. roll up banners, within conference rooms during the event
- Sponsors acknowledgement at closing of event by the conference Chairman

ASA = £6,000

ASA + ACHL = £12,000

ASA + ACHL + airfreight pharma/Pharma.aero = £18,000

Airport Services Association Conference 2023

SOLD



Catch Box

- Total 3 - 4 catch-boxes in the conference room
- Company logo branding on the catch-box, a pivotal tool for delegates to get involved in the conversation
- Your logo will be printed on the sleeve of the catch-box
- Logo to appear on all promotional material (online and print)
- Listed as a sponsor on all event materials
- Logo in a prominent guideline position on the day of the event
- All pre-event marketing mailings will include your logo and link to your website

ASA = £5,000

ASA + ACHL = £10,000

ASA + ACHL + airfreight pharma/Pharma.aero = £15,000

Airport Services Association Conference 2023





Delegate Bags

- Delegate bags - to be given to all delegates upon registration. (bags to be supplied by sponsor)
- Logo to appear on marketing emails
- Logo to appear in the conference room

ASA = £5,000

ASA + ACHL = £10,000

ASA + ACHL + airfreight pharma/Pharma.aero = £15,000

Water Cooler

- Sponsor's branding printed on spring water cooler
- Branded reusable bottles to be supplied by sponsor
- Listed as a sponsor on all event material
- Your logo in a prominent headline position on promotional material (online and print)
- All pre-event marketing mailings will include your logo and link to your website
- 1 delegate pass

ASA = £5,000

ASA + ACHL = £10,000

ASA + ACHL + airfreight pharma/Pharma.aero = £15,000



Sweet Station

- Bonus brand exposure in co-located areas within the ACHL, Airfreight Pharma & ASA Global Event
- Sponsor's logo and corporate image on the Sweet Station
- Listed as a sponsor on all event material
- All pre-event marketing mailings will include your logo and link to your website
- Logo in a prominent headline position on the day of the event
- Branding on the sweet bags
- Your logo in a prominent headline position on promotion material (online and in print)

ASA = £5,000

ASA + ACHL = £10,000

ASA + ACHL + airfreight pharma/Pharma.aero = £15,000



Refreshment Break 1, 2 & 3

- Bonus brand exposure in co-located areas with the ACHL, Airfreight Pharma & ASA Global Event
- Three refreshment breaks (Includes all refreshment breaks across 2 days)
- Logo and company recognition on the refreshment table during sponsored break
- Sponsor's logo to appear on event website, marketing material and conference rooms
- 1 delegate pass
- Recognition of sponsors within conference venue
- Sponsors acknowledgement at closing of event

ASA = £4,500

ASA + ACHL = £9,000

ASA + ACHL + airfreight pharma/Pharma.aero = £13,500

Airport Services Association Conference 2023



Speakers Lounge

- High profile company branding in the speaker lounge
- Company branding to appear on tables
- Logo, web link and company profile on the conference website
- Sponsor acknowledgement at closing of event

ASA = £4,500

ASA + ACHL = £9,000

ASA + ACHL + airfreight pharma/Pharma.aero = £13,500





1-2-1 Meeting Room Sponsor

- Bonus brand exposure in co-located areas within the ACHL, Airfreight Pharma & ASA Global Event
- High profile company branding in the 1-2-1 meeting area
- Company branding to appear on table flags on 1-2-1 meeting tables
- Logo, web link, and company profile on the conference website
- Sponsor acknowledgement at closing of event

ASA = £4,000

ASA + ACHL = £8,000

ASA + ACHL + airfreight pharma/Pharma.aero = £12,000

Hotel Room Gift Drop - To existing and potential customers

- The sponsorship for the hotel room gift drop at the co-located ACHL, Airfreight Pharma & ASA Global Event
- Deliver your company's message or gift item to all conference attendees hotel rooms, room drops provide a captive audience and great visibility for your company message
- Gifts to be supplied by sponsor
- Your logo in a prominent headline position on promotional material (online and in print)
- All pre-event marketing mailings will include your logo and link to your website
- Listed as a sponsor on all event materials
- Logo in a prominent headline position on the day of the event

ASA = £3,000

ASA + ACHL = £6,000

ASA + ACHL + airfreight pharma/Pharma.aero = £9,000

Airport Services Association Conference 2023





Sponsored Conference Session

- Company logo branding included on print and digital marketing leading up to and during the event
- Your logo in a prominent headline position on promotional material (online and in print)
- All pre-event marketing mailings will include your logo and link to your website
- Listed as a sponsor on all event materials
- Logo to be displayed on the conference session you have sponsored.
- 1 delegate pass

£2,500